

HM7042-5

Triple Power Supply

User Manual



扫码二维码关注我们
或查找微信公众号：海洋仪器



DECLARATION OF CONFORMITY

Manufacturer:

HAMEG Instruments GmbH
Industriestraße 6 · D-63533 Mainhausen

The HAMEG Instruments GmbH herewith declares conformity of the product:

Product name: Triple Power Supply
Type: HM7042-5

complies with the provisions of the Directive of the Council of the European Union on the approximation of the laws of the Member States

- relating to electrical equipment for use within defined voltage limits (2006/95/EC) [LVD]
- relating to electromagnetic compatibility (2004/108/EC) [EMCD]
relating to restriction of the use of hazardous substances in electrical and electronic equipment (2011/65/EC) [RoHS].

Conformity with LVD and EMCD is proven by compliance with the following standards:

EN 61010-1: 04/2015
EN 61326-1: 07/2013
EN 55011: 11/2014
EN 61000-3-2: 03/2015
EN 61000-3-3: 03/2014
EN 61000-4-2: 12/2009
EN 61000-4-3: 04/2011
EN 61000-4-4: 04/2013
EN 61000-4-5: 03/2015
EN 61000-4-6: 08/2014
EN 61000-4-11: 02/2005
EN 61000-6-3: 11/2012

For the assessment of electromagnetic compatibility, the limits of radio interference for Class B equipment as well as the immunity to interference for operation in industry have been used as a basis.

Date: 8.6.2015

Signature:

Holger Asmussen
General Manager

General remarks regarding the CE marking

HAMEG measuring instruments comply with the EMI norms. Our tests for conformity are based upon the relevant norms. Whenever different maximum limits are optional HAMEG will select the most stringent ones. As regards emissions class 1B limits for small business will be applied. As regards susceptibility the limits for industrial environments will be applied. All connecting cables will influence emissions as well as susceptibility considerably. The cables used will differ substantially depending on the application. During practical operation the following guidelines should be absolutely observed in order to minimize EMI:

1. Data connections

Measuring instruments may only be connected to external associated equipment (printers, computers etc.) by using well shielded cables. Unless shorter lengths are prescribed a maximum length of 3 m must not be exceeded for all data interconnections (input, output, signals, control). In case an instrument interface would allow connecting several cables only one may be connected. In general, data connections should be made using double-shielded cables. For IEEE-bus purposes the double screened cable HZ72 from is suitable.

2. Signal connections

In general, all connections between a measuring instrument and the device under test should be made as short as possible. Unless a shorter length is prescribed a maximum length of 3 m must not be exceeded, also, such connections must not leave the premises. All signal connections must be shielded (e.g. coax such as RG58/U). With signal generators double-shielded cables are mandatory. It is especially important to establish good ground connections.

3. External influences

In the vicinity of strong magnetic or/and electric fields even a careful measuring set-up may not be sufficient to guard against the intrusion of undesired signals. This will not cause destruction or malfunction of HAMEG instruments, however, small deviations from the guaranteed specifications may occur under such conditions.

Content

General remarks regarding the CE marking	16
Technical Data	18
1 Important hints	20
1.1 Symbols	20
1.2 Unpacking	20
1.3 Positioning	20
1.4 Transport / Storage	20
1.5 Safety instructions	20
1.6 Proper operating conditions	20
1.7 Warranty and Repair	21
1.8 Maintenance	21
1.9 Mains voltage and Changing the line fuse	21
2 Operating Controls	22
3 Basics of Power Supplies	23
3.1 Linear power supplies	23
3.2 Switched-mode Power Supplies (SMPS)	23
3.3 Parallel and Series Operation	23
3.4 Current Limit	24
3.5 Electronic Fuse	24
4 Concept of the HM7042-5	25
4.1 Output power of the HM7042-5	25
4.2 Switching the display on/off	25
5 Introduction to the operation	25
5.1 First time operation	25
5.2 Turning on the HM7042-5	25
6 Operating controls and displays	26
6.1 Kanal I + III	26
6.2 Kanal II	26
6.3 Current Limiting	27
6.4 Electronic Fuse	27

HM7042-5

Triple Power Supply

Technical Data



Key facts

- ▮ 2 x 0...32V/0...2A 1 x 0...5.5V/0...5A
- ▮ High-performance and inexpensive laboratory power supply
- ▮ Floating, overload and short-circuit proof outputs
- ▮ Separate voltage and current displays for each output
4 digits at channel 1+3; 3 digits at channel 2
- ▮ Display resolution:
10mV/1mA at channel 1+3; 10mV/10mA at channel 2
- ▮ Protection of sensitive loads by current limit or electronic fuse
- ▮ Pushbutton to activate/deactivate all outputs
- ▮ Low residual ripple, high output power, excellent regulation
- ▮ Parallel (up to 9A) and series (up to 69.5V) operation
- ▮ Temperature-controlled fan

Technical Data

Triple Power Supply

HM7042-5

All data valid at 23°C after 30 minutes warm-up.

Outputs

2 x 0...32V/2A and 0...5,5V/5A	ON/OFF pushbutton control, SMPS followed by a linear regulator, floating outputs for parallel/serial operation, current limit and electronic fuse
--------------------------------	---

Output 1 + 3 (32V)

Range:	2 x 0...32V, continuously adjustable 2 knobs (coarse/fine)
Ripple:	≤100µVEff (3Hz...300kHz) typ., ≤1mV (10Hz...1MHz)
Current:	max. 2A
Current limit/electronic fuse:	0...2A, continuously adjustable (knob)
Recovery time (10...90% load variation):	80µs within ±1 mV of nominal value 30µs within ±10mV of nominal value 0µs within ±100mV of nominal value
Max. transient deviation:	typ. 75mV
Recovery time (50% basic load, 10% load variation):	30µs within ±1 mV of nominal value 5µs within ±10mV of nominal value 0µs within ±100mV of nominal value
Max. transient deviation:	typ. 17mV
Display:	
7-Segment LED:	32,00V (4 Digit)/2,000A (4 Digit)
Resolution:	0,01V/1mA
Display accuracy:	±3 digit voltage/±4 digit current
LED:	indicates current limit

Output 2 (5,5V)

Range:	0...5.5V, continuously adjustable (knobs)
Ripple:	≤100µVEff (3Hz...300kHz) typ., ≤1mV (10Hz...1MHz)
Current:	max. 5A
Current limit/electronic fuse:	0...5A, continuously adjustable (knob)
Recovery time (10...90% load variation):	80µs within ±1 mV of nominal value 10µs within ±100mV of nominal value
Max. transient deviation:	typ. 170mV
Recovery time (50% basic load, 10% load variation):	30µs within ±1 mV of nominal value 15µs within ±10mV of nominal value 0µs within ±100mV of nominal value
Max. transient deviation:	typ. 60mV
Display:	
7-Segment LED	5,50V (3 Digit)/5,00A (3 Digit)
Resolution:	0,01V/10mA
Display accuracy:	±3 digit voltage/±1 digit current
LED	indicates current limit

Maximum ratings

Max. voltage applicable to output terminals:

CH 1 + CH 3	33V
CH 2	6V
Reverse voltage:	max. 0,4V
Reverse current:	max. 5A
Voltage to earth:	max. 150V

Miscellaneous

Safety class:	Safety class I (EN61010-1)
Mains supply:	115V/230V ±10%; 50...60Hz, CAT II
Mains Fuse:	115V: 2 x 5A; slow blow 5 x 20mm 230V: 2 x 2,5A; slow blow 5 x 20mm
Power consumption:	max. 330VA/250W
Operating temperature:	+5...+40°C
Storage temperature:	-20...+70°C
Rel. humidity:	5...80% (non condensing)
Dimensions (W x H x D):	285 x 75 x 365mm
Weight:	approx. 7,4kg

Accessories supplied:

Operating manual, line cord

Recommended accessories:

HZ10S	5 x silicone test lead (black)
HZ10R	5 x silicone test lead (red)
HZ10B	5 x silicone test lead (blue)
HZ42	19" Rackmount Kit 2RU

1 Important hints



1.1 Symbols

- Symbol 1: Caution, general danger zone – Refer to product documentation
 Symbol 2: Risk of electric shock
 Symbol 3: Ground

1.2 Unpacking

Please check for completeness of parts while unpacking. Also check for any mechanical damage or loose parts. In case of transport damage inform the supplier immediately and do not operate the instrument.

1.3 Positioning

Two positions are possible: According to picture 1 the front feet are used to lift the instrument so its front points slightly upward (approx. 10 degrees). If the feet are not used (picture 2) the instrument can be combined with many other HAMEG instruments. In case several instruments are stacked (picture 3) the feet rest in the recesses of the instrument below so the instruments can not be inadvertently moved. Please do not stack more than three instruments. A higher stack will become unstable, also heat dissipation may be impaired.

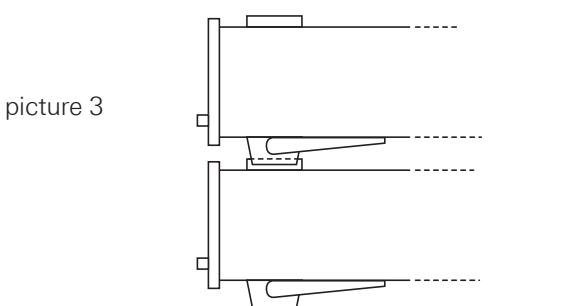
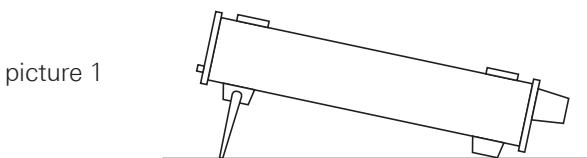

1.4 Transport / Storage

Please keep the carton in case the instrument may require later shipment for repair. Losses and damages during transport as a result of improper packaging are excluded from warranty!

Dry indoors storage is required. After exposure to extreme temperatures 2 h should be held off on turning the instrument on.

1.5 Safety instructions

The instrument conforms to VDE 0411/1 safety standards applicable to measuring instruments and left the factory in proper condition according to this standard. Hence it conforms also to the European standard EN 61010-1 resp. to the international standard IEC 61010-1. Please observe all warnings in this manual in order to preserve safety and guarantee operation without any danger to the operator. According to safety class 1 requirements all parts of the housing and the chassis are connected to the safety ground terminal of the power connector. For safety reasons the instrument must only be operated from 3 terminal power connectors or via isolation transformers. In case of doubt the power connector should be checked according to DIN VDE 0100/610.

It is prohibited to disconnect the earthed protective connection inside or outside the instrument!

- The line voltage of the instrument must correspond to the line voltage used.
- Opening of the instrument is allowed only to qualified personnel
- Prior to opening the instrument must be disconnected from the line and all other inputs/outputs.

In any of the following cases the instrument must be taken out of service and locked away from unauthorized use:

- Visible damages
- Damage to the power cord
- Damage to the fuse holder
- Loose parts
- No operation
- After longterm storage in an inappropriate environment , e.g. open air or high humidity.
- Excessive transport stress

Exceeding the Low Voltage Protection!
For the series connection of all output voltages, it is possible to exceed the low voltage protection of 42 V. Please note that in this case any contact with live components is life-threatening. It is assumed that only qualified and trained personnel service the power supplies and the connected loads.

1.6 Proper operating conditions

The instruments are destined for use in dry clean rooms. Operation in an environment with high dust content, high humidity, danger of explosion or chemical vapors is prohibited. Operating temperature is +5°C ... +40°C. Storage or transport limits are –20°C ... +70°C. In case of condensation 2 hours are to be allowed for drying prior to operation. For safety reasons operation is only allowed from 3 terminal

connectors with a safety ground connection or via isolation transformers of class 2. The instrument may be used in any position, however, sufficient ventilation must be assured as convection cooling is used. For continuous operation prefer a horizontal or slightly upward position using the feet.



Do not obstruct the ventilation holes!

Specifications with tolerances are valid after a 30 minute warm-up period and at 23 degrees C. Specifications without tolerances are typical values of an average instrument.

1.7 Warranty and Repair

Our instruments are subject to strict quality controls. Prior to leaving the manufacturing site, each instrument undergoes a 10-hour burn-in test. This is followed by extensive functional quality testing to examine all operating modes and to guarantee compliance with the specified technical data. The testing is performed with testing equipment that is calibrated to national standards. The statutory warranty provisions shall be governed by the laws of the country in which the product was purchased. In case of any complaints, please contact your supplier. Any adjustments, replacements of parts, maintenance and repair may be carried out only by authorized technical personnel. Only original parts may be used for replacing parts relevant to safety (e.g. power switches, power transformers, fuses). A safety test must always be performed after parts relevant to safety have been replaced (visual inspection, PE conductor test, insulation resistance measurement, leakage current measurement, functional test). This helps ensure the continued safety of the product.



The product may only be opened by authorized and qualified personnel. Prior to working on the product or before the product is opened, it must be disconnected from the AC supply network. Otherwise, personnel will be exposed to the risk of an electric shock.

1.8 Maintenance

The instrument does not require any maintenance. Dirt may be removed by a soft moist cloth, if necessary adding a mild detergent. (Water and 1 %.) Grease may be removed with benzene (petrol ether). Displays and windows may only be cleaned with a moist cloth.

Before cleaning the measuring instrument, please make sure that it has been switched off and disconnected from all power supplies (e.g. AC supply network or battery).

No parts of the instruments may be cleaned with chemical cleaning agents (such as alcohol, acetone or cellulose thinner)!

1.9 Mains voltage and Changing the line fuse



A main voltage of 115V and 230V can be chosen. Please check whether the mains voltage used corresponds with the voltage indicated by the mains voltage selector on the rear panel. If not, the voltage has to be changed. In this case the line fuse has to be changed, too.

After changing the main voltage, the line fuse has to be changed. Otherwise the instrument may be destroyed.

The fuses are accessible from the outside and contained in the line voltage connector housing. Before changing a fuse disconnect the instrument from the line, the line cord must be removed. Check fuse holder and line cord for any damages. Use a suitable screw driver of appr. 2 mm to depress the plastic fuse holder releases on both sides, the housing is marked where the screw driver should be applied. After its release the fuse holder will come out by itself pushed forward by springs. The fuses can then be exchanged, please take care not to bend the contact springs. Reinsertion of the fuse holder is only possible in one position and by pressing against the springs until the locks engage. It is forbidden to repair defective fuses or to bridge them by any means. Any damage caused this way will void the warranty.

Types of fuses:

Size 5 x 20 mm; 250V~,
IEC 60127-2/5
EN 60127-2/5

Line voltage	Correct fuse type
230 V	2 x 2,5 A slow blow
115 V	2 x 5 A slow blow

2 Operating Controls

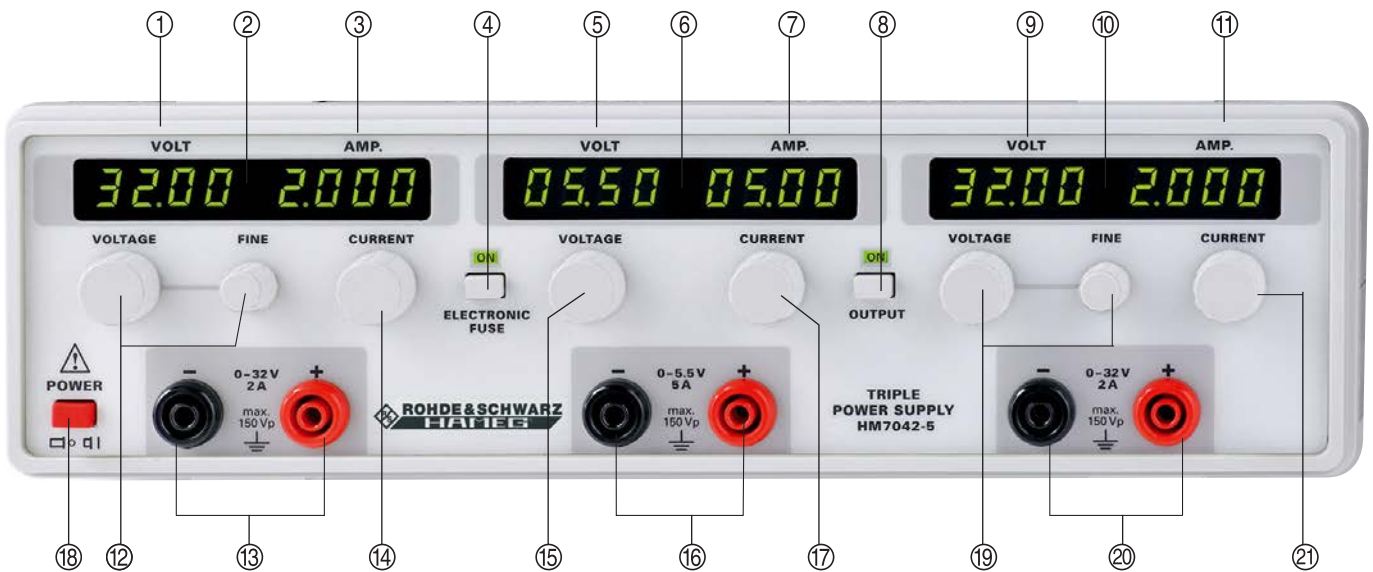

Front panel

- ① ⑤ ⑨ **VOLT** - Voltage display
- ③ ⑦ ⑪ **AMP** - Current display
- ② ⑥ ⑩ **LED** - Current limit indicator
- ④ **ELECTRONIC FUSE** - Selector of functions electronic fuse/current limit; LED will light if the electronic fuse function is enabled
- ⑧ **OUTPUT** - Switching ON/OFF of all channels; LED indicates status on
- ⑫ ⑱ **VOLTAGE/FINE** - Fine/coarse adjustment of output voltage 0...32V
- ⑮ **VOLTAGE** - Adjustment of output voltage 0...5.5V

⑭ ⑰ ⑳ **CURRENT** - Adjustment of current limit I_{max} of both current limit and electronic fuse threshold

⑬ ⑳ **0 - 32V / 2A** - Safety terminals of the 32-V-outputs

⑯ **0 - 5.5V / 5A** - Safety terminals of the 5-V-output

⑱ **Power button**

Rear panel

⑳ **Voltage selector** - Choice of mains voltage (115V/230V)

㉓ **Power receptacle** with line fuse



3 Basics of Power Supplies

3.1 Linear power supplies

Linear regulated power supplies excel by their highly constant output voltage, low ripple and fast regulation, even under high line and load transients. Good power supplies feature a ripple of less than 1 mV_{rms} which is mostly negligible. Further they are free from EMI emission in contrast to SMPS. A conventional mains transformer isolates the line from the secondary which is rectified and supplies an unregulated voltage to a series pass transistor. Capacitors at the input and output of the regulator serve as buffers and decrease the ripple. A high precision reference voltage is fed to one input of an amplifier, the second input is connected mostly to a fraction of the output voltage, the output of this amplifier controls the series pass transistor. This analog amplifier is generally quite fast and is able to keep the output voltage within tight limits.

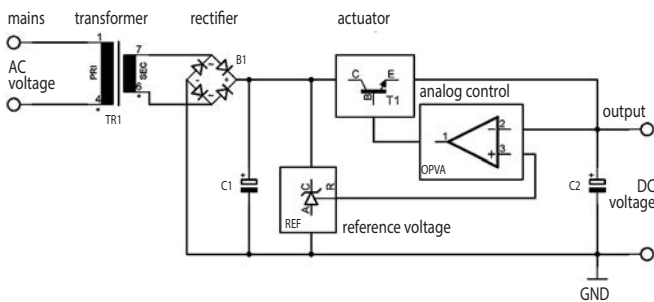

3.2 Switched-mode Power Supplies (SMPS)

SMPS operate with very much higher efficiencies than linear regulated power supplies. The DC voltage to be converted is chopped at a high frequency rate thus requiring only comparatively tiny and light ferrite chokes or transformers with low losses, also, the switching transistor is switched fully on and off hence switching losses are low. In principle regulation of the output voltage is achieved by changing the duty cycle of the switch driving waveform.

1st Off-line SMPS

The line voltage is rectified, the buffer capacitor required is of fairly small capacitance value because the energy stored is proportional to the voltage squared ($E = 1/2 \times C \times U_2$).

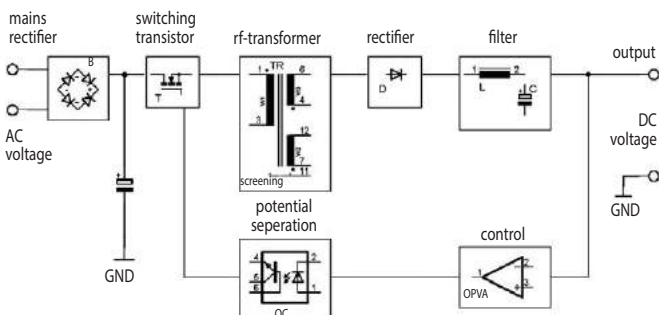

2nd Secondary SMPS

These still require a 50 or 60 Hz mains transformer, the secondary output voltage is rectified, smoothed and then chopped.

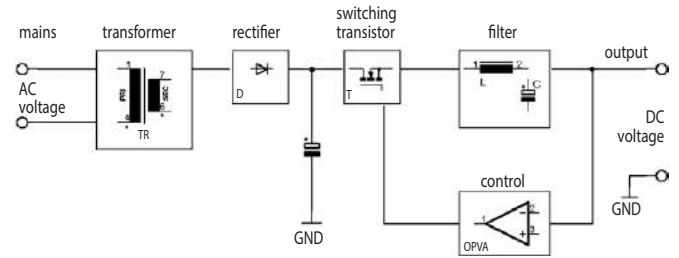

The capacitance values needed here for filtering the 100 resp. 120 Hz ripple are higher due to the lower voltage. All SMPS feature a very much higher efficiency from appr. 70 up to over 95 % compared to any linear supply. They are lighter, smaller. The capacitors on the output(s) of a SMPS may be quite small due to the high frequency, but the choice depends also on other factors like energy required for buffering or ac ripple from the load (e.g. motors). In principle the size of the major components decreases with increasing operating frequency, however, the efficiency drops appreciably above appr. 250 kHz as the losses in all components rise sharply.

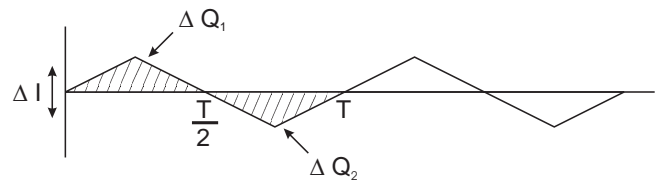

3.3 Parallel and Series Operation

It is mandatory that the power supplies used are definitely specified for these operating modes. This is the case with HM7043-5 power supplies. As a rule, the output voltages to be combined are independent of each other, hence, it is allowed to connect the outputs of one supply with those of another or more.

Series Operation

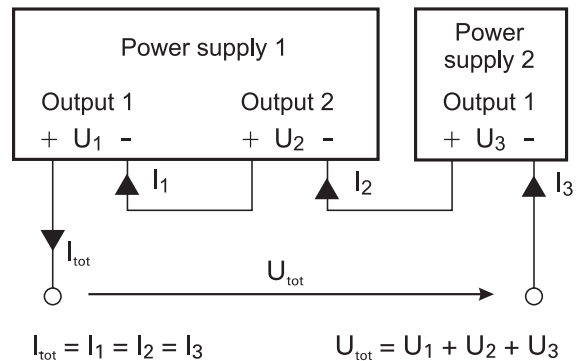

The current limit of the outputs in series should be adjusted to the same value. If one output reaches the current limit the total voltage will break down.



In this mode the output voltages add, the output current is the same for all supplies. As the sum of all voltages may well surpass the 42 V limit touching of live parts may be fatal! Only qualified and well instructed personnel is allowed to operate such installations.

Parallel Operation

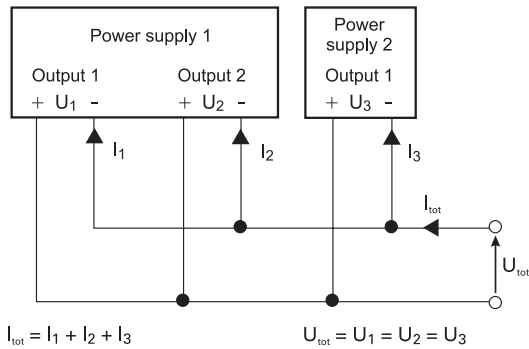

In order to increase the total available current the outputs of supplies can be paralleled. The output voltages of the supplies involved are adjusted as accurately as possible to the same value. In this mode it is possible that one or more supplies enter the current limit mode. The output voltage remains in regulation as long as still at least one supply is in the voltage control mode. It is recommended but not absolutely necessary to fine adjust the voltages such that the individual current contributions remain nearly equal. Of course, the maximum available output current is the sum of the individual supplies' maximum currents.

Example:

A load requires 12 V at 2.7 A. Each 32 V output of the HM7042-5 can deliver 2A. First set both supplies to 12V. Then connect both black and both red safety connectors respectively in parallel. The load is connected to one of the supplies. With the pushbutton OUTPUT Ⓢ the voltage will be turned on. It is normal that one output will current limit at 2 A while the other will contribute the balance of 0.7 A in voltage regulation.



In case you should parallel power supplies of other manufacturers with HM7042-5 power supplies make sure all are specified for this mode of operation. If one supply of those connected in parallel should have insufficient overload protection it may be destroyed. HM7042-5 power supplies are specified for series and parallel operation.

3.4 Current Limit

Current limit means that a maximum current can be set. This is e.g. useful in order to protect a sensitive test circuit. In case of an inadvertent short in the test circuit the current will be limited to the value set which will in most cases prevent damage.

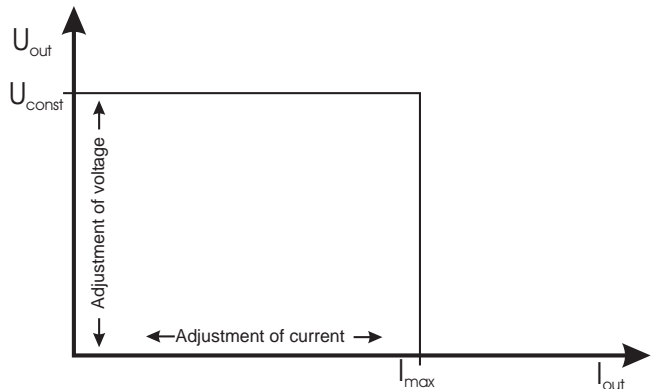

The picture shows that the output voltage V_{out} remains stable, while the current I increases until the current limit selected will be reached. At this moment the instrument will change from constant voltage regulation to constant current regulation. Any further load increase will cause the current to remain stable while the voltage decreases ultimately to zero.

3.5 Electronic Fuse

In order to provide a still better protection than current limiting offers the HM7042-5 features an electronic fuse. As soon as I_{max} is reached all outputs will be immediately simultaneously disabled. They may be turned on again by depressing OUTPUT Ⓢ.

4 Concept of the HM7042-5

In this instrument the advantages of a SMPS, especially high efficiency, and those of a linear regulator, e.g. high quality regulation, are combined. A high power DC/DC converter is used as a preregulator for the following linear regulators, this reduces the high losses typical of purely linear regulation. The HM7042-5 has 3 independent and isolated voltage sources. In addition to the standard mode of operation as a triple output supply all outputs may be series or parallel connected.



Exceeding the Low Voltage Protection!

For the series connection of all output voltages, it is possible to exceed the low voltage protection of 42 V. Please note that in this case any contact with live components is life-threatening. It is assumed that only qualified and trained personnel service the power supplies and the connected loads.

In series connection the maximum available current is limited to 2 A. Paralleling the two 32 V outputs will yield 4 A at a maximum of 32 V. Please note that series as well as parallel connection may influence some specifications valid such as output impedance, noise, regulation.

4.1 Output power of the HM7042-5

The maximum combined output power is 155.5 W. The HM7042-5 has a temperature-controlled fan the rpm of which will increase with rising temperature. This will ensure sufficient cooling under all normal operating conditions.

4.2 Switching the display on/off

All HM7042-5 power supplies feature a pushbutton which turns the outputs ON/OFF while the supply remains functioning. This allows to preset all voltages to their respective desired values prior to turning the outputs on by depressing OUTPUT Ⓞ.

5.1 First time operation

Please observe especially the following notes:

- The line voltage indicated on the rear panel corresponds to the available line voltage, also, the correct fuses for this line voltage are installed. The fuses are contained in the line voltage connector housing.
- The connection to the mains is either by plugging into a socket with safety ground terminal or via an isolation transformer of protection class II.
- No visible damage to the instrument.
- No visible damage to the line cord.
- No loose parts floating around in the instrument.

北京海洋兴业科技股份有限公司（证券代码：839145）

5 Introduction to the operation

5.2 Turning on the HM7042-5

After turning on all outputs will remain disabled, protecting the loads. Prior to pressing OUTPUT Ⓞ all output voltages should be set to their desired values. Also, after turn-on the instrument will be in the operating mode "Current limit". The maximum current available can be set by CURRENT Ⓐ Ⓑ Ⓒ. The mode "Electronic fuse" may be selected after turn-on, but after each turn-off-on cycle "Current limit" will be set.

6 Operating controls and displays

6.1 Channel I + III

0 – 32 V / 2 A

Output voltage, adjustable 0 – 32 V. Safety terminals for 4 mm plugs. The outputs are short circuit-proof with no time limit.

① ⑨ VOLT

4 digit displays (7 segment LEDs), of the actual values of all voltages, the resolution is 10 mV. The display are always operative, even when the outputs are disabled allowing pre-setting of all output voltages before the loads are connected to them. We recommend to follow always the procedure of setting the output voltages first and then turn the outputs on.

② ⑩ LED

These LEDs will light up if current limit is reached.

③ ⑪ AMP

4 digit displays (7 segment LEDs) of the actual output currents, resolution 1 mA. We recommend to set the output current (I_{max}) before setting the output voltage and then turn on the outputs.

⑫ ⑬ VOLTAGE/FINE

Rotary controls for the coarse/fine adjustment of the 0 – 32 V outputs.

⑬ ⑭ 0 – 32V / 2A

Outputs, 4 mm safety connectors

⑭ ⑮ CURRENT

Rotary controls for setting the maximum currents of the 0 – 32 V outputs. If a control is turned CCW to 0 A all outputs

will be turned off immediately if the function “electronic fuse” was activated. In case “Current limit” was selected the LEDs ② ⑩ will light up, the voltage will drop to zero.

0 – 5.5 V / 5 A

This output voltage can be adjusted 0 – 5.5 V. 4 mm safety connectors. This output is short-circuit proof without a time limit.

6.2 Channel II

⑤ VOLT

3 digit displays (7 segment LEDs) of the actual output voltage, resolution 10 mV. This display will show the output voltage even if the output was switched off. We recommend to follow always the procedure of setting the output voltage first and then turn the output on.

⑥ LED

If the current limit I_{max} is reached this LED will light up.

⑦ AMP.

3 digit displays (7 segment LEDs) of actual output currents, resolution 10 mA. We recommend to set the output current I_{max} prior to turning on the output voltages.

⑮ VOLTAGE

Rotary control for setting the 0 – 5.5 V

⑯ 0 – 5.5V / 5A

Output, 4 mm safety connectors.

⑰ CURRENT

Rotary control for setting the maximum output current 0 – 5A. If the control is turned CCW to 0 A all outputs will be turned off immediately if the mode “electronic fuse” was selected. In “current limit” mode the LED ⑥ will light up, the voltage will drop to zero.

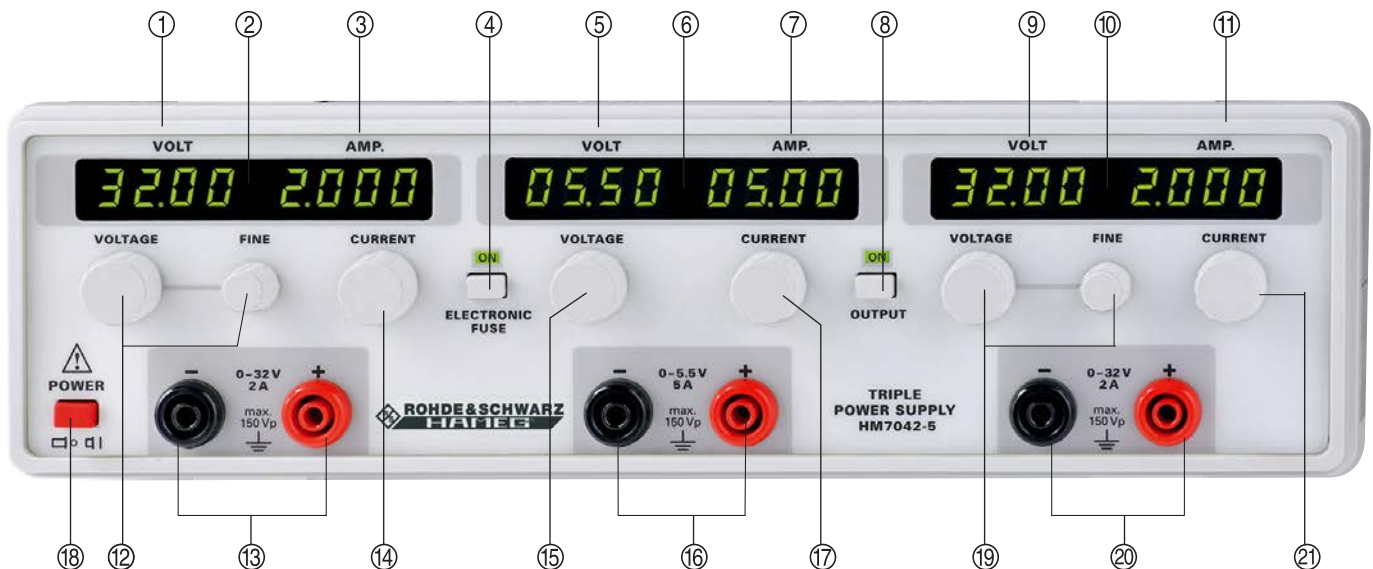

④ ELECTRONIC FUSE

This pushbutton will activate the electronic fuse mode, indicated by LED [ON].

⑧ OUTPUT

Pushbutton for turning all 3 channels simultaneously ON/OFF, indicated by the LED [ON]. The voltage displays will remain unaffected.

6.3 Current Limiting

After turn-on of the power supply it will always start in the CURRENT LIMIT mode. Using the CURRENT ⑭ ⑰ ⑳ controls the maximum output current I_{max} can be set for each output separately. Onset of current limiting in one channel will not influence the others. In order to adjust I_{max} the appropriate output has to be short-circuited first, then I_{max} can be set, the associated LED ② ⑥ or ⑩ will light up and indicate the current limit mode.

6.4 Electronic Fuse

Prior to selection of this mode the current limits have to be set using the CURRENT ⑭ ⑰ ⑳ controls. As outlined each output has to be short-circuited first before adjusting the appropriate CURRENT control. After setting I_{max} , the short has to be removed. Then Electronic Fuse ④ is depressed, the LED [ON] will light up indicating that the HM7042-5 is in the Electronic Fuse mode. In this mode all outputs will be immediately deactivated if the I_{max} of one channel is reached. In order to leave this mode press Electronic Fuse ④ again.

The current limits can be set using the controls CURRENT ⑭ ⑰ ⑳ 0 – 2 A / 0 – 5 A. If a control is set CCW to 0 A indeed the current will be zero, so the output capacitances will be discharged slowly to 0 V. In “Current Limit” mode the CCW position of a control will cause the associated LED ② ⑥ ⑩ to light up, the output voltage will decrease slowly. In the Electronic Fuse mode the CCW position of any CURRENT control will result in immediate switching off of all channels after depressing OUPUT ⑧.



北京海洋兴业科技股份有限公司 (证券代码: 839145)

北京市西三旗东黄平路19号龙旗广场4号楼 (E座) 906室

电话: 010-62176775 62178811 62176785

企业QQ: 800057747 维修QQ: 508005118

企业官网: www.hyxyyq.com

邮编: 100096

传真: 010-62176619

邮箱: market@oitek.com.cn

购线网: www.gooxian.net



扫描二维码关注我们
查找微信公众号: 海洋仪器